

Aluminum Horizontal to Incline Conveyor



Prodeva, Inc. designs and builds equipment to last. Our aluminum line is constructed of formed 3/16" thick aluminum plate sides and rails that are bolted together with steel cross members. This is the same design as our heavy duty steel channel iron conveyors and it gives us the most rigid design in the industry.

Box filling, under the press, grinder feed, cooling, work station feeding. The list of things the Prodeva horizontal to incline aluminum conveyors can be used for is limitless. And because of the rugged design they will be able to do these jobs for many years to come. With standard sizes ranging from 6" to 36" and in length from 3' to 15' there are few jobs these conveyors can't handle.



Prodeva, Inc.

Quality Conveyors Since 1958

Standard Features

- 3/16" formed Aluminum Plate
- Side rails overlap belt by 1/2" per side
- 3 1/4" diameter v-groove pulleys
- PVC 120 belting with v-guide with non marking white FDA belt
- 1 1/2" cleats on 18" centers standard
- Shaft mounted gear box
- 1/4 HP to 1 HP motors
- On/off toggle switch
- 15' power cord
- Self aligning bearings
- Screw type take ups
- Adjustable legs
- Mounted on casters
- 4" high side rails
- Adjustable Angle Conveyor

Standard Options

- Variable speed control
- Indexing control / box fill
- Cleat heights / spacing
- Special sized hoppers
- Alternate motor locations
- Soft drop zones
- Grinder feed controls
- Nose over sections
- Metal free zones for metal detection
- Discharge chute
- Feed hoppers
- Special Belting

For three generations, Prodeva, Inc. has produced products that withstand the most extreme conditions. We manufacture our conveyors from only the highest quality materials and back them with a **TWO YEAR** warranty. In addition to the standard line, we will custom design conveyors to fit your needs. The next time you have a conveyor project call Prodeva, so we can use our nearly 50 years of experience to design manufacture and install your system.

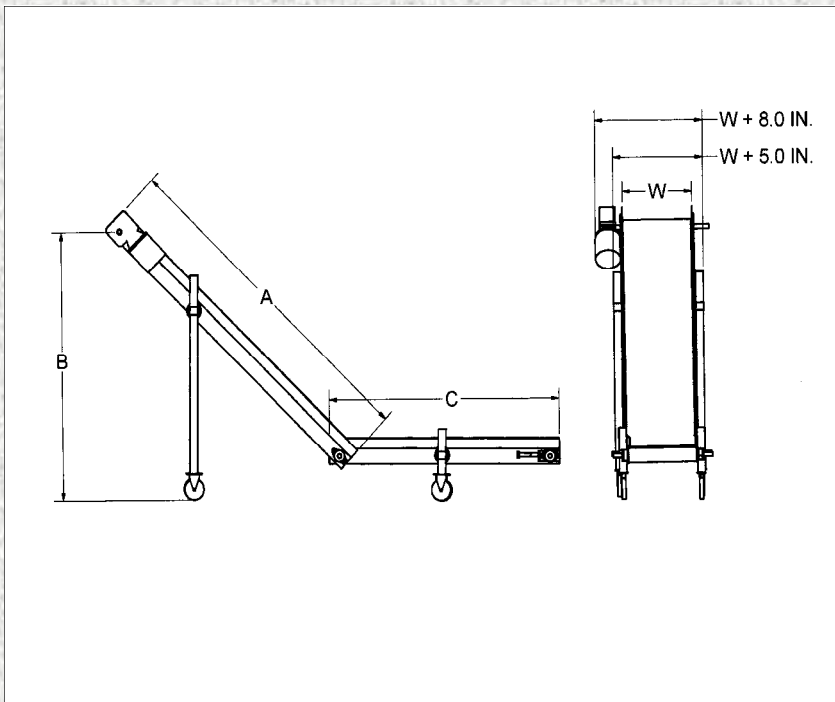

W = Belt width
 A = Length of belt incline section
 B = Discharge height
 C = Lower horizontal length
Standard Lengths 3' to 15'
Standard Widths 6" to 36" in 3" increments



Prodeva, Inc.
100 Jerry Dr.
Jackson Center, OH 45334
800-999-3271
937-596-5145 FAX